



DOUGH  
DIVIDERS



# B 300 D Dough Divider

The B 300 D is a versatile and highly weight accurate dough divider with up to 4 dough chambers. A wide variety of dough types can be processed in a dough friendly way.





## WP Haton the leading brand in dough processing since 1949

WP Haton produces the most advanced and best bread make-up machines in the world contributing to high weight accuracy, excellent structure and most friendly and careful handling of the dough without compromising on high speed, consistency and constant quality on every piece of the dough piece produced.

- Automated dough processing systems for virtually all types of bread
- Tailormade line concepts in dough processing equipment
- Unique system of modularization
- BreadLab: the experience center where bakers from all over the world can test our equipment with their own ingredients

# B 300 D Dough Divider

### Highlights

- Dough friendly dividing at high capacity
- Up to four dough chambers
- Large weight range and high weight precision
- Maximum capacity of up to 6,400 pcs/h
- Long lifespan by using wear-resistant materials
- Solid construction of drive unit and dividing system
- Low oil consumption
- Easy access for cleaning and maintenance



## B 300 D

The B 300 D is a dough divider with the possibility for up to 4 dough chambers. The portioning mechanism of the B 300 D is dough friendly and highly weight accurate. It is designed in such a way to make it robust, and at the same time easy to operate and maintain. A wide range of dough types can be processed on the B 300 D dough divider: ranging from soft to stiff dough, as well as wheat dough and combined rye dough types.

## Specifications

- 1, 1 and 2, 2 and 4 pocket machine
- Dividing unit with automatic oiling on unit, 6 fixed dosing valves and 5 litres oil tank
- Discharge conveyor cross L = 720 mm
- Mechanical discharge flap with synthetic scraper
- Main piston, dividing chamber and hopper base: wear-resistant chrome nickel alloy
- Measuring piston in food safe bronze
- Hopper stainless steel 95 litres, including safety ring with pressure sensitive edge
- Hopper base with Teflon coating
- Knife made of hardened stainless steel



Find out more about WP Haton and our products by scanning this QR-code with your mobile phone, or visit [WWW.WP-HATON.COM](http://WWW.WP-HATON.COM)

## Technical drawing

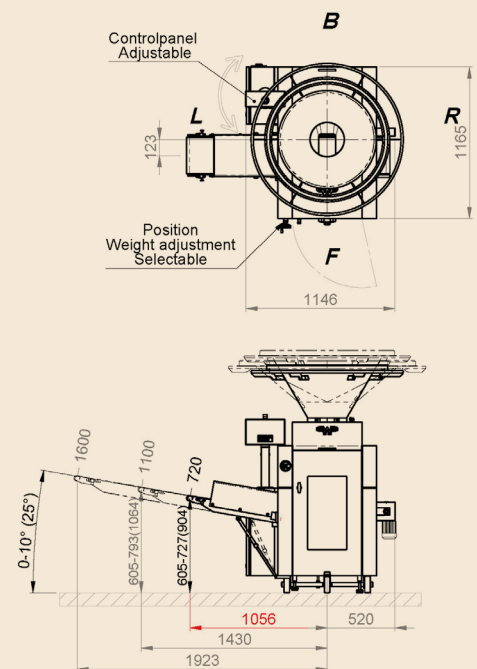
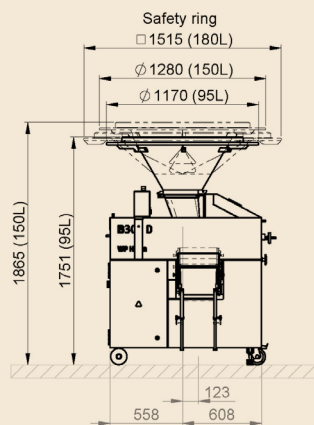
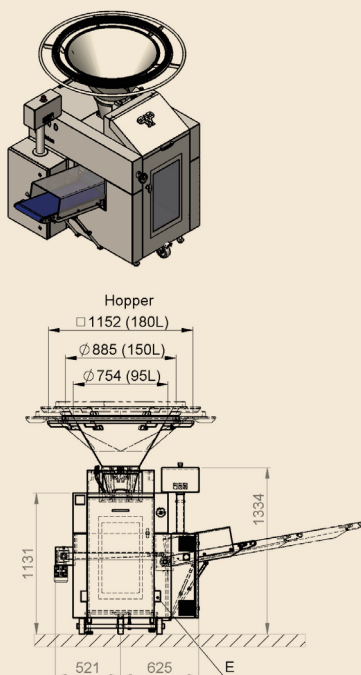

## B 300 D Measurements

TYPE	POCKETS / WEIGHT RANGE	CAPACITY (FIXED)	CAPACITY VARIABLE	DIMENSIONS
1010	1 / 100 - 1200 gr	510, 650, 725, 810, 910, 1010, 1130 or 1270 pcs/h	507 - 1160 pcs/h	Length 1360 mm
1510	1 / 200 - 1800 gr		637 - 1456 pcs/h	Width 1610 mm
2010	1 / 400 - 2400 gr		700 - 1600 pcs/h	Height 1720 mm
1012 1 pocket, see type 1010	1 / 100 - 1200 gr 2 / 50 - 300 gr	1 / 510, 650, 725, 810, 910, 1010, 1130 or 1270 pcs/h 2 / 1010, 1300, 1450, 1620, 1820, 2020, 2260 or 2540 pcs/h	1 / 507 - 1160 pcs/h 2 / 1014 - 2320 pcs/h	
1512 1 pocket, see type 1510	1 / 200 - 1800 gr 2 / 50 - 600 gr		1 / 637 - 1456 pcs/h 2 / 1274 - 2912 pcs/h	
2012 1 pocket, see type 2010	1 / 400 - 2400 gr 2 / 100 - 1050 gr		1 / 700 - 1600 pcs/h 2 / 1400 - 3200 pcs/h	
2024 2 pockets, see type 1012, 1512, 2012	2 / 100 - 1050 gr	2 / 1014 - 2320 pcs/h 4 / 2028 - 4640 pcs/h		
	4 / 50 - 400 gr	2 / 1274 - 2912 pcs/h 4 / 2548 - 5824 pcs/h		
		2 / 1400 - 3200 pcs/h 4 / 2800 - 6400 pcs/h		

## Options

- Hinged hopper stainless steel 150 or 180 litres
- Hopper inside Teflon coated
- Oiling on hopper including oil shortage signalisation
- PLC with touch panel with pre-set counter, recipe control, frequency inverter and Servo weight adjustment
- Discharge conveyor cross mounted, 1100 or 1600 mm
- Mechanical or electrical flour duster
- Customer specific Blue Box

### WP HATON BV

Industrieterrein 13, 5981 NK Panningen, The Netherlands

Phone: +31 77307-1860, E-mail: info@wp-haton.com

www.wp-haton.com