



DOUGH
DIVIDERS



B 300 Dough Divider

The B 300 is a single pocket dough divider with dough friendly and highly weight accurate portioning mechanism. It is suitable for most common types of dough as well as sensitive dough.

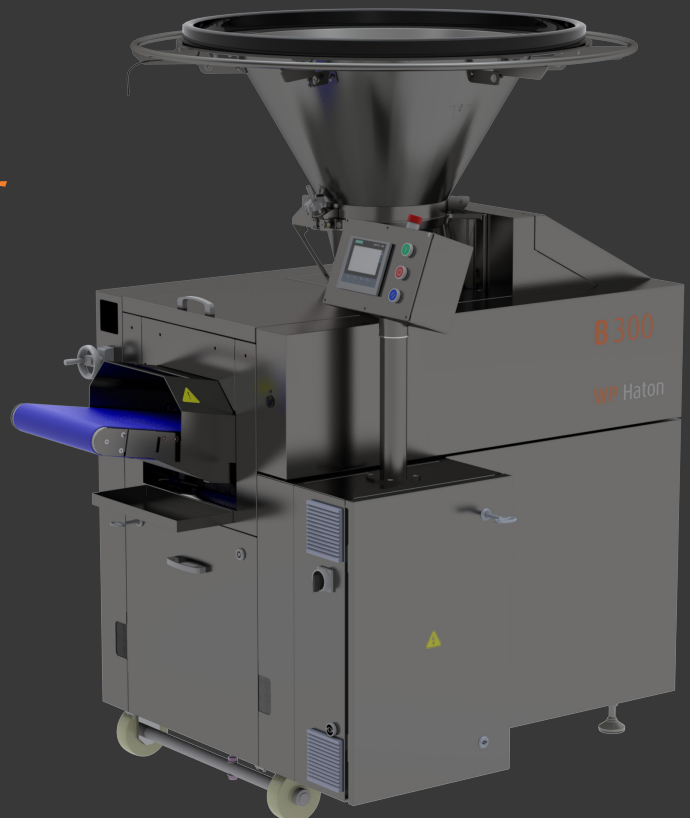



WP Haton the leading brand in dough processing since 1949

WP Haton produces the most advanced and best bread make-up machines in the world contributing to high weight accuracy, excellent structure and most friendly and careful handling of the dough without compromising on high speed, consistency and constant quality on every piece of the dough piece produced.

- Automated dough processing systems for virtually all types of bread
- Tailormade line concepts in dough processing equipment
- Unique system of modularization
- BreadLab: the experience center where bakers from all over the world can test our equipment with their own ingredients

B 300 Dough Divider

Highlights

- Long lifespan by using wear-resistant materials
- Main piston, dividing chamber and hopper base made of wear-resistant chrome nickel alloy
- Measuring piston in food safe bronze
- Solid construction of drive unit and dividing system
- High weight accuracy
- Recipe control
- Low oil consumption
- Easy access for cleaning and maintenance



B 300

The B 300 is a single pocket dough divider, suitable for a wide variety of dough types. Whether soft or stiff dough, wheat, or combined rye dough, they all are easy to process; combined with the recipe control, this is a highly versatile divider. It is designed in such a way to make it robust, and at the same time easy to operate and maintain. The dividing mechanism is dough friendly and highly weight accurate.

Specifications

- Single pocket machine
- Dividing unit with automatic oiling on unit, 6 fixed dosing valves and 5 litres oil tank
- Main piston, dividing chamber and hopper base: wear-resistant chrome nickel alloy
- Measuring piston in food safe bronze
- Hopper stainless steel, 95 litres, including safety ring with pressure sensitive edge
- Hopper base with Teflon coating
- Knife made of hardened stainless steel
- Discharge conveyor straight, L = 1435 mm



Find out more about WP Haton and our products by scanning this QR-code with your mobile phone, or visit WWW.WP-HATON.COM

Technical drawing

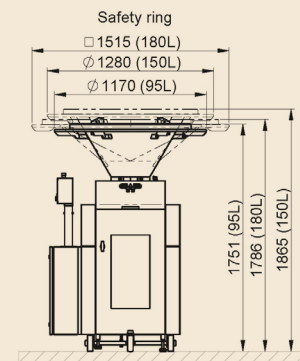
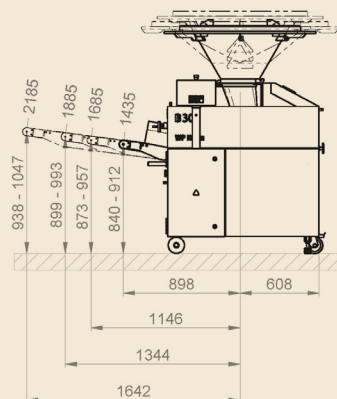
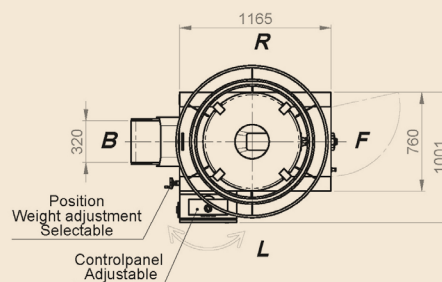
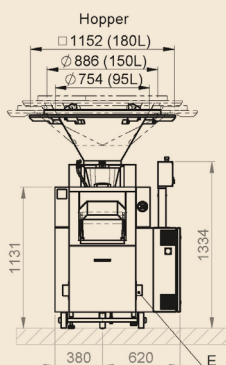
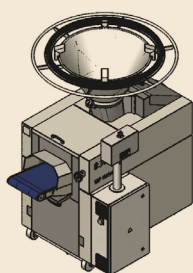

B 300 Measurements

TYPE	WEIGHT RANGE	CAPACITY (FIXED)	CAPACITY VARIABLE	DIMENSIONS
1000	100 - 1200 gr	510, 650, 725, 810, 910, 1010, 1130 or 1270 pcs/h	507 - 1160 pcs/h	Length 1610 mm
1500	200 - 1800 gr		637 - 1456 pcs/h	Width 1010 mm
2000	400 - 2400 gr		700 - 1600 pcs/h	Height 1720 mm

Options

- Hinged hopper stainless steel 150 or 180 litres
- Hopper inside Teflon coated
- Oiling on hopper including oil shortage signalisation
- Oiling on measuring piston
- PLC with touch panel with pre-set counter, recipe control, frequency inverter and Servo weight adjustment
- Discharge conveyor straight, 1685, 1885 or 2185 mm
- Lubrication on conveyor belt
- Mechanical flour duster
- Mechanical discharge flap with synthetic scraper
- Customer specific Blue Box

WP HATON BV

Industrieterrein 13, 5981 NK Panningen, The Netherlands

Phone: +31 77307-1860, E-mail: info@wp-haton.com

www.wp-haton.com