



DOUGH
DIVIDERS



B 700 Dough Divider

The B 700 is a robust and reliable dough divider, yet highly versatile at the same time. A wide variety of dough types can be processed at high capacity.





WP Haton the leading brand in dough processing since 1949

WP Haton produces the most advanced and best bread make-up machines in the world contributing to high weight accuracy, excellent structure and most friendly and careful handling of the dough without compromising on high speed, consistency and constant quality on every piece of the dough piece produced.

- Automated dough processing systems for virtually all types of bread
- Tailormade line concepts in dough processing equipment
- Unique system of modularization
- BreadLab: the experience center where bakers from all over the world can test our equipment with their own ingredients

B 700 Dough Divider

Highlights

- Extremely robust designed industrial dough divider
- Ni-Resist unit with food safe bronze pistons
- Suitable for large weight range
- Multiple split and pocket options
- Solid construction of drive system and dividing mechanism
- Open front design for visual control on discharge conveyor
- Easily removable stainless-steel dough hopper, Teflon coated
- Minimum use of oil



B 700

The B 700 is a sturdy dough divider with a wide weight range and a capacity of up to 9,000 pcs/h. The B 700 is a dough divider with possibilities for several splits and pockets, making it a highly versatile instrument to process a variety of dough types: from wheat, wheat/rye, rye and multigrain dough to stiff pizza dough and soft dough.

Specifications

- Dividing unit Ni-Resist with automatic oiling, 21 dosing valves, 10 litres oil tank
- Measuring piston in food safe bronze
- Knife made of hardened stainless steel
- Hopper stainless steel 120 litres, inside and base Teflon coated
- Discharge conveyor cross 500 mm, with quick-lock system, scraper and catch tray
- Set of 2 oil catch pans which can be taken out at the front and back side or combined at 1 side
- Belt lubrication system
- Pneumatic discharge flap with scraper
- Frequency inverter for variable speed



Find out more about WP Haton and our products by scanning this QR-code with your mobile phone, or visit WWW.WP-HATON.COM

Technical drawing

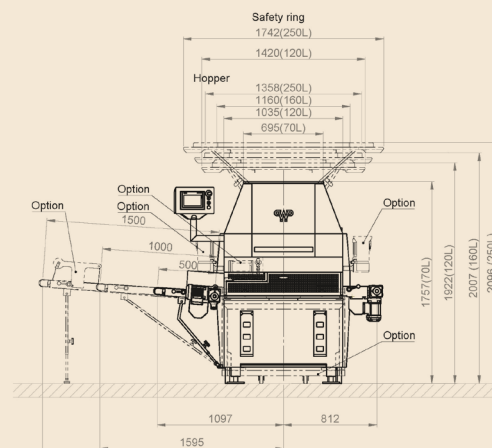
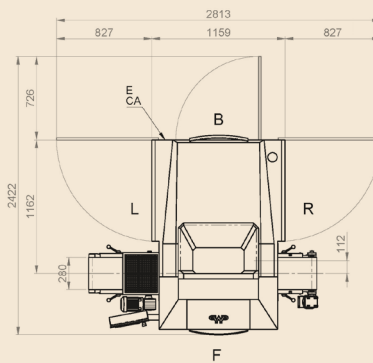
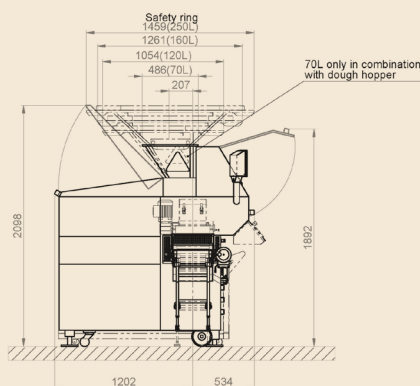
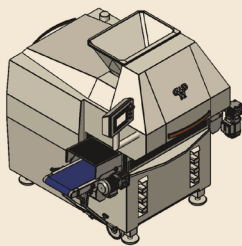

B 700 Measurements

TYPE	PARTITIONS	WEIGHT RANGE	CAPACITY	DIMENSIONS
B 700 - 2	25 mm	400 - 2400 gr	1000 - 3000 pcs/h	Length 1950 mm
	50 mm	400 - 2100 gr	1000 - 3000 pcs/h	Width 1800 mm
B 700 - 3	25 mm	300 - 1400 gr	1500 - 4500 pcs/h	Height 1760 mm
B 700 - 4	25 mm	200 - 1000 gr	2000 - 6000 pcs/h	
B 700 - 4-split	2 x L / 2 x R - 25 mm	150 - 1000 gr	2000 - 6000 pcs/h	
B 700 - 5	25 mm	150 - 780 gr	2500 - 7500 pcs/h	
B 700 - 6	25 mm	150 - 600 gr	3000 - 9000 pcs/h	
B 700 - 6-split	3 x L / 3 x R - 25 mm	150 - 600 gr	3000 - 9000 pcs/h	
B 700 - 2/4	25 mm	400 - 2150 gr	1000 - 3000 pcs/h	
		200 - 925 gr	2000 - 6000 pcs/h	
B 700 - 3/6	25 mm	300 - 1300 gr	1500 - 4500 pcs/h	
		150 - 520 gr	3000 - 9000 pcs/h	

Options

- Hopper stainless steel 70, 160, 250 litres, inside Teflon coated
- Oiling on hopper including oil shortage signalisation
- Flour duster with own drive motor
- Drag-net on discharge conveyor
- CleanTec version
- Dividing unit in SR material
- Customer specific Blue Box

WP HATON BV

Industrieterrein 13, 5981 NK Panningen, The Netherlands

Phone: +31 77307-1860, E-mail: info@wp-haton.com

www.wp-haton.com