



DOUGH  
PROOFERS



# BIP 72-M

## Intermediate Proofer

**This intermediate dough proofer is suitable for a wide variety of dough types.** It is developed for fully automatic proofing of the dough pieces between the rounder and long moulder.





## WP Haton the leading brand in dough processing since 1949

WP Haton produces the most advanced and best bread make-up machines in the world contributing to high weight accuracy, excellent structure and most friendly and careful handling of the dough without compromising on high speed, consistency and constant quality on every piece of the dough piece produced.

- Automated dough processing systems for virtually all types of bread
- Tailormade line concepts in dough processing equipment
- Unique system of modularization
- BreadLab: the experience center where bakers from all over the world can test our equipment with their own ingredients

# BIP 72-M Intermediate Proofer

### Highlights

- Intermediate proofer with stainless steel frame and swings
- Pallet infeed
- Broad range of options for customisation
- Modular frame made of stainless steel
- Processing without flour dusting
- Teflon coated transfer box for easy dough transfer between pockets
- Removable and washable synthetic dough pockets
- UV light for protection against mould
- Variable proofing times



## BIP 72-M

The BIP 72-M is an intermediate proofer suitable for many common dough types, such as wheat and wheat/rye dough. It processes dough pieces without the use of any dusting flour. Via the infeed system, the rounded dough pieces are dropped into the proofer pockets, while the proofer runs intermittent for 100% filling or continuously. The ultraviolet lamps prevent mould forming on the inside of the proofer, and the transparent plexiglass windows allow for visual inspection of the dough pieces.

## Specifications

- Infeed by photocell or V-step belt
- Proofer runs intermittently / continuously
- Blue pockets polyethylene, removable, washable, Ø 190 mm
- Frame, turning device, proofer trays and panels in stainless steel
- Parts in contact with dough are Teflon coated
- Chain with chain guides in stainless steel
- Drive SEW gearbox with shear pin protection
- Integrated switch board panel
- PLC with touch panel
- Discharge chute with outfeed on last row

## Technical drawing

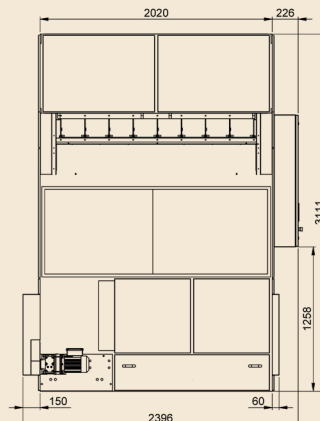
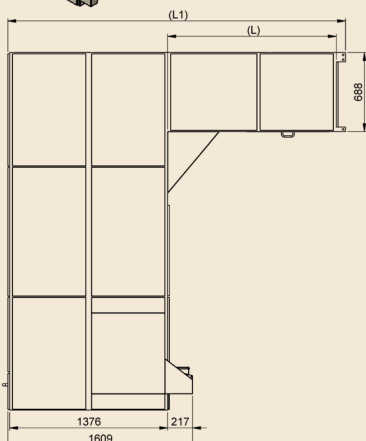
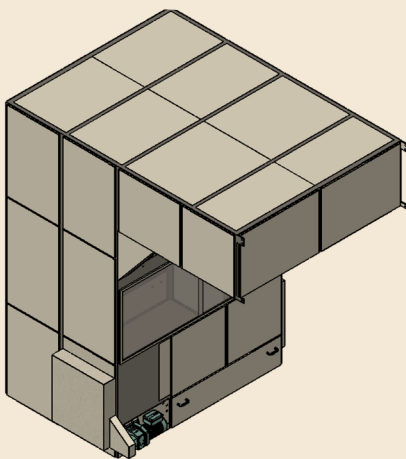

**Find out more** about  
WP Haton and our products  
by scanning this QR-code with  
your mobile phone, or visit  
[WWW.WP-HATON.COM](http://WWW.WP-HATON.COM)

## BIP 72-M Measurements

TYPE	CONTENTS			DIMENSIONS
	NET – GROSS POCKETS PER INFEED TYPE			
BIP 72-M Weight range 200 - 1800 gr	Photocell infeed Capacity: up to 1200 pcs/h	V-step belt, single infeed Capacity: up to 1800 pcs/h	V-step belt, dual infeed Capacity: up to 3600 pcs/h	Height: 3111 mm, head length variable
8 rows	376 - 416 392 - 432 408 - 448 424 - 464	360 - 416 376 - 432 392 - 448 408 - 464	360 - 416 376 - 432 392 - 448 408 - 464	1467 mm 1734 mm 2001 mm 2268 mm
12 rows	564 - 624 588 - 648 612 - 672 636 - 696	540 - 624 564 - 648 588 - 672 612 - 696	540 - 624 564 - 648 588 - 672 612 - 696	1467 mm 1734 mm 2001 mm 2268 mm

## Options

- Infeed at front, outfeed at backside
- Air blower on infeed
- Exhaust fan
- Fully automatic climate control
- Central switching
- PLC control
- Adjustable outfeed chute
- Stainless steel net for discharge chute
- Reversible discharge conveyor with own drive
- Customer specific Blue Box

### WP HATON BV

Industrieterrein 13, 5981 NK Panningen, The Netherlands

Phone: +31 77307-1860, E-mail: [info@wp-haton.com](mailto:info@wp-haton.com)

[www.wp-haton.com](http://www.wp-haton.com)