



DOUGH HOPPER

Controlled dough slider

By using the dough hopper, the pressure, and the amount of dough in the dough hopper of the divider are constant, which is very important for an accurate weight consistency.





WP Haton the leading brand in dough processing since 1949

WP Haton produces the most advanced and best bread make-up machines in the world contributing to high weight accuracy, excellent structure and most friendly and careful handling of the dough without compromising on high speed, consistency and constant quality on every piece of the dough piece produced.

- Automated dough processing systems for virtually all types of bread
- Tailormade line concepts in dough processing equipment
- Unique system of modularization
- BreadLab: the experience center where bakers from all over the world can test our equipment with their own ingredients

DOUGH HOPPER

Controlled dough slide

Highlights

- Robust design in stainless steel frame
- Knife made of hardened stainless steel
- Automated operational control
- Dough level detection by photocell
- Available in different hopper sizes up to 1000 litres
- Adjustable dough slide opening for different types of dough
- Teflon coating or HDPE lining possible on the hopper



DOUGH HOPPER

The Dough Hopper is used in automatic dough handling systems for feeding and portioning the complete batch of dough up to 1000 litres into the divider below. The dough is being fed from the mixer to the dough hopper by means of an elevator. The level of the dough in the divider hopper is being controlled by a photocell. When the minimum level has been reached, the pneumatic slide on the bottom of the hopper is being opened to feed the requested quantity of dough to the divider hopper. Both the pressure and the amount of dough in the dough hopper of the divider remain at a constant level, which assures an accurate weight consistency of the individual dough piece.

Specifications

- Robust construction
- Aluminium platform with safety rail
- Ladder stainless steel, removable, with aluminium steps and railing
- Pneumatic controlled dough slide
- Dough level detection of the divider with two photocells
- Oil spraying device, pneumatic (five nozzles)
- For placing above bread and roll dividers of the WP BakeryGroup. Other dividers upon request.



Find out more about WP Haton and our products by scanning this QR-code with your mobile phone, or visit WWW.WP-HATON.COM

Technical drawing

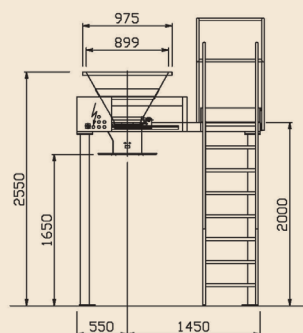
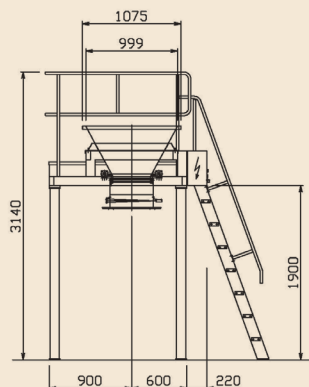
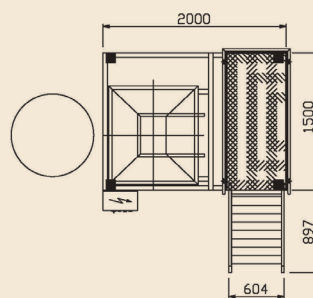
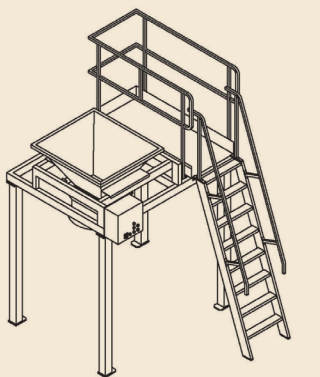

POSITION LADDER

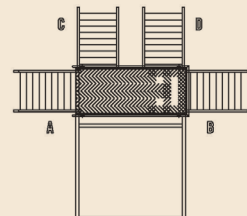

DIRECTION DOUGH SLIDE

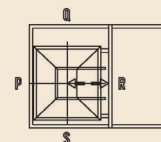

DOUGH HOPPER Measurements

TYPE

Dough hopper contents depending on divider and dough hopper size of the divider

| | |
|---|------------|
| Contents for B/V 300 | 240 litres |
| Contents for Parta U | 285 litres |
| Contents for Parta U XL | 285 litres |
| Contents for B/V 700 | 330 litres |
| Different size of dough hopper upon request | |

Options

- Capacity hopper up to 1000 litres
- Hopper outside stainless steel, inside Teflon coating or HDPE lining
- Dough level detection in dough hopper
- Acoustic or visual signal for communication with the bowl tipper
- Hopper movable for cleaning purposes
- Customer specific Blue Box

WP HATON BV

Industrieterrein 13, 5981 NK Panningen, The Netherlands

Phone: +31 77307-1860, E-mail: info@wp-haton.com

www.wp-haton.com