



DOUGH
DIVIDERS



PARTAU Dough Divider

Extremely accurate dough divider with a proven long lifetime. This divider can be used for nearly any type of dough in almost every type of bakery.





WP Haton the leading brand in dough processing since 1949

WP Haton produces the most advanced and best bread make-up machines in the world contributing to high weight accuracy, excellent structure and most friendly and careful handling of the dough without compromising on high speed, consistency and constant quality on every piece of the dough piece produced.

- Automated dough processing systems for virtually all types of bread
- Tailormade line concepts in dough processing equipment
- Unique system of modularization
- BreadLab: the experience center where bakers from all over the world can test our equipment with their own ingredients

PARTAU Dough Divider

Highlights

- Industrial but compact machine
- High weight accuracy
- Suitable for a wide range of dough types
- Maximum adaption to batch sizes with various hopper sizes
- Easy and quick cleaning of hopper and all parts coming in contact with dough
- Maximum adaption to individual wishes
- Low machine height with maximum accessibility



PARTA U

The Parta U is an extremely weight accurate dough divider with a proven long lifetime. The robust design of this divider allows for nearly every dough type to be processed and at the same time a variety of dough hopper sizes enables a variation in batch size. The Parta U can be cleaned safely and easily thanks to the sideways hinged dough hopper with automated safety stop. Extremely robust design, proven quality for over 40 years.

Specifications

- Multiple pockets possible: 1, 2 pockets, 2 and 1 or 3 pockets
- Dividing unit Ni-Resist with automatic oiling on unit, with 6 fixed dosing valves
- Discharge conveyor, left or right-hand L = 725, 925 or 1275 mm
- Main piston, dividing chamber and hopper base wear-resistant chrome-nickel alloy
- Hopper base with Teflon coating
- Measuring piston(s) Ni-Resist
- Knife made of hardened stainless steel



Find out more about WP Haton and our products by scanning this QR-code with your mobile phone, or visit WWW.WP-HATON.COM

Technical drawing

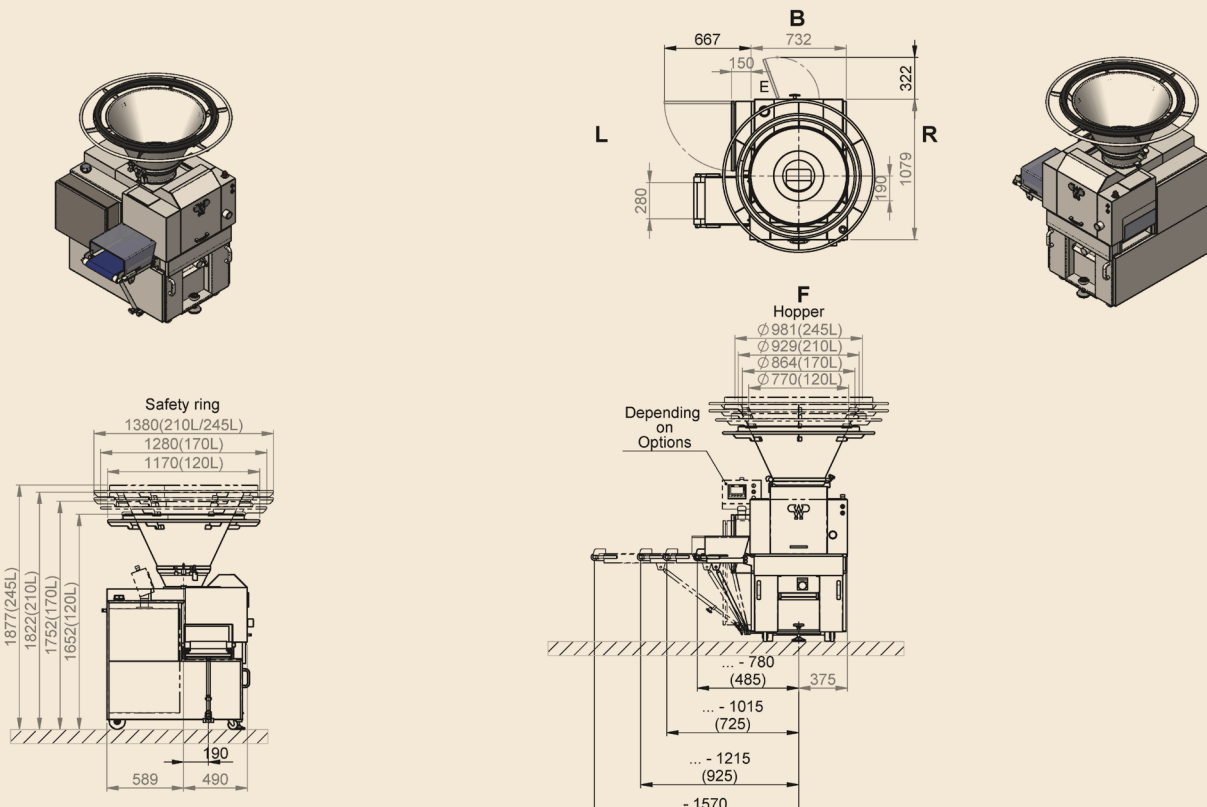

PARTA U Measurements

TYPE	WEIGHT RANGE	CAPACITY (FIXED)	CAPACITY VARIABLE	DIMENSIONS
2001	300 - 2800 gr	510 - 1630 pcs/h	450 - 1408 pcs/h	Length 1390 mm
2002	110 - 1250 gr	1020 - 3260 pcs/h	900 - 2816 pcs/h	Width 1080 mm
2012	300 - 2800 gr	510 - 1630 pcs/h	450 - 1408 pcs/h	Height 1620 mm
	110 - 1250 gr	1020 - 3260 pcs/h	900 - 2816 pcs/h	

Options

- Hinged hopper stainless steel 170, 210 or 245 litres
- Hopper inside Teflon coated
- Hopper base Nedox coated
- Oiling on hopper including oil shortage signalisation
- Lubrication on dividing unit and internal discharge conveyor
- Drag-net on discharge conveyor
- Discharge roller with scraper (dough weights < 200 gr)
- Two mechanical flour dusters
- PLC with touch panel
- Recipe control
- Customer specific Blue Box

WP HATON BV

Industrieterrein 13, 5981 NK Panningen, The Netherlands

Phone: +31 77307-1860, E-mail: info@wp-haton.com

www.wp-haton.com