



DOUGH
DIVIDERS



PARTAU XL Dough Divider

Extremely accurate dough divider with a proven long lifetime, with a robust design for highly automated dough processing locations. This divider can be used for nearly any type of dough.





WP Haton the leading brand in dough processing since 1949

WP Haton produces the most advanced and best bread make-up machines in the world contributing to high weight accuracy, excellent structure and most friendly and careful handling of the dough without compromising on high speed, consistency and constant quality on every piece of the dough piece produced.

- Automated dough processing systems for virtually all types of bread
- Tailormade line concepts in dough processing equipment
- Unique system of modularization
- BreadLab: the experience center where bakers from all over the world can test our equipment with their own ingredients

PARTA U XL Dough Divider

Highlights

- Three chambers for high output
- High weight accuracy
- Suitable for a wide range of dough types
- Maximum adaption to batch sizes with various hopper sizes
- Easy and quick cleaning of hopper and all parts coming in contact with dough
- Dough pieces are transported sideways
- Maximum adaption to individual wishes
- Low machine height with maximum accessibility



PARTA U XL

The Parta U XL is a highly accurate and user-friendly three-chamber dough divider, able to process almost all types of dough. The suction volume of the Parta U XL can be regulated for exact portioning of the dough. The weight range of the individual dough pieces is between 110 and 1,000 grams, with a maximum processing of 4,200 dough pieces being portioned per hour. The large dough hopper can contain up to 120 litres. The relatively low working height allows for maximum accessibility, which further improves the user-friendliness.

Specifications

- Three pocket dough divider
- Dividing unit Ni-Resist with automatic oiling on unit, with 6 fixed dosing valves
- Movable discharge conveyor, cross, left, or right-hand L = 700 / 900 / 1100 mm
- Main piston, dividing chamber and hopper base wear-resistant chrome-nickel alloy
- Hopper base with Teflon coating
- Measuring piston(s) Ni-Resist
- Knife made of hardened stainless steel



Find out more about
WP Haton and our products
by scanning this QR-code
with your mobile phone, or
visit WWW.WP-HATON.COM

Technical drawing

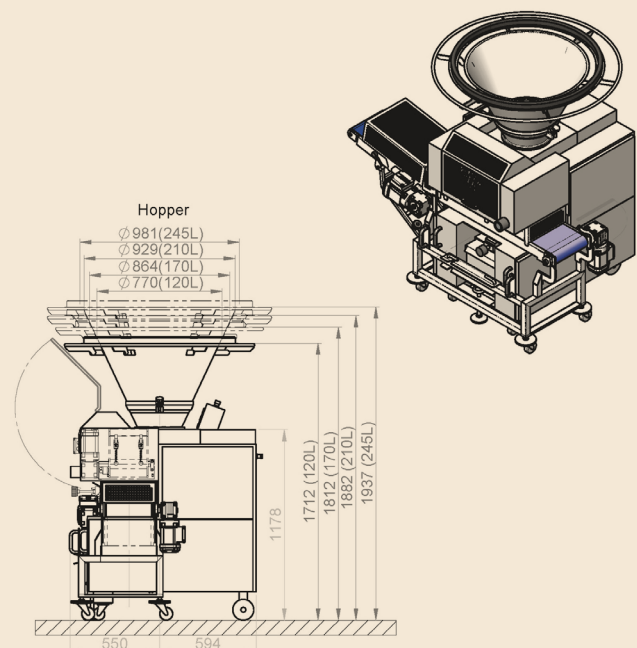
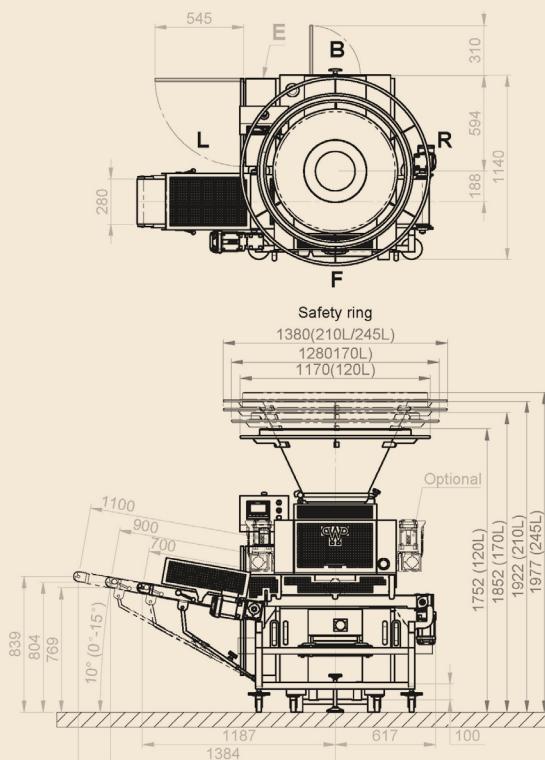

PARTA U XL Measurements

TYPE	WEIGHT RANGE	CAPACITY (FIXED)	CAPACITY (VARIABLE)	DIMENSIONS
3 pockets	110 - 1000 gr	1530 - 4890 pcs/h	1350 - 4224 pcs/h	Length 1390 mm
				Width 1080 mm
				Height 1620 mm

Options

- Hinged hopper stainless steel 170, 210 or 245 litres
- Hopper inside Teflon coated
- Hopper base Nedox coated
- Oiling on hopper including oil shortage signalisation
- 5 Litres oil tank
- Lubrication on dividing unit and internal discharge conveyor
- Drag-net on discharge conveyor
- Discharge roller with scraper (dough weights < 200 gr)
- Flour duster with own drive
- PLC with touch panel
- Recipe control
- Customer specific Blue Box

WP HATON BV

Industrieterrein 13, 5981 NK Panningen, The Netherlands

Phone: +31 77307-1860, E-mail: info@wp-haton.com

www.wp-haton.com