



DOUGH  
DIVIDERS



# V 300 Dough Divider

The V 300 is a single pocket dough divider with **Voluminator for adjustable pressure**. It is a dough friendly and highly weight accurate divider suitable for a wide variety of dough types.

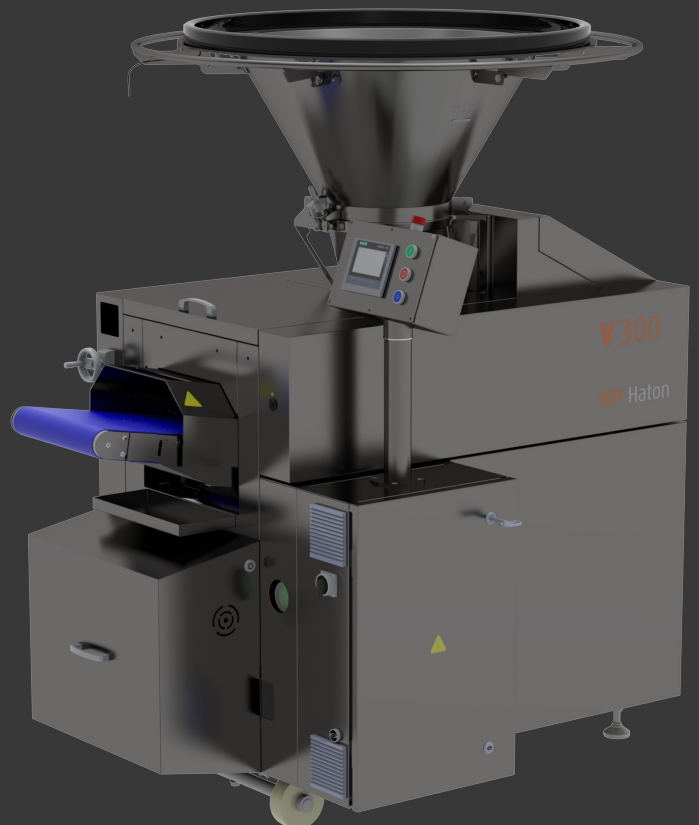



## WP Haton the leading brand in dough processing since 1949

WP Haton produces the most advanced and best bread make-up machines in the world contributing to high weight accuracy, excellent structure and most friendly and careful handling of the dough without compromising on high speed, consistency and constant quality on every piece of the dough piece produced.

- Automated dough processing systems for virtually all types of bread
- Tailormade line concepts in dough processing equipment
- Unique system of modularization
- BreadLab: the experience center where bakers from all over the world can test our equipment with their own ingredients

# V 300 Dough Divider

### Highlights

- Suitable for most types of dough, including pre-proofed dough
- Voluminator for adjusting pressure to maintain airy structure of the dough
- Dough friendly dividing at high capacity
- High weight precision
- Long lifespan by using wear-resistant materials
- Solid construction of drive unit and dividing system
- Low oil consumption
- Easy access for cleaning and maintenance



## V 300

The V 300 is a single pocket machine equipped with the Voluminator which enables adjustable pressure within the chamber to maintain the airy structure of the dough. The V 300 is a dough friendly dough divider with a highly weight accurate portioning mechanism. It is designed in such a way to make it robust, and at the same time easy to operate and maintain. A wide range of dough types can be processed, ranging from soft to stiff dough, as well as wheat dough and combined rye dough types.

## Specifications

- Single pocket machine with Voluminator
- Dividing unit with automatic oiling on unit, 8 fixed dosing valves
- Automatic oiling on discharge conveyor and measuring piston
- Five litres oil tank
- Mechanical discharge flap with synthetic scraper
- Main piston, dividing chamber and hopper base: wear-resistant chrome nickel alloy
- Measuring piston in food safe bronze
- Hopper stainless steel, 95 litres, including safety ring with pressure sensitive edge
- Hopper base with Teflon coating
- Knife made of hardened stainless steel



Find out more about WP Haton and our products by scanning this QR-code with your mobile phone, or visit [WWW.WP-HATON.COM](http://WWW.WP-HATON.COM)

## Technical drawing

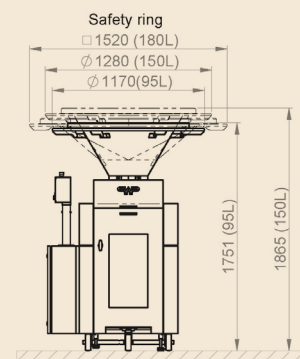
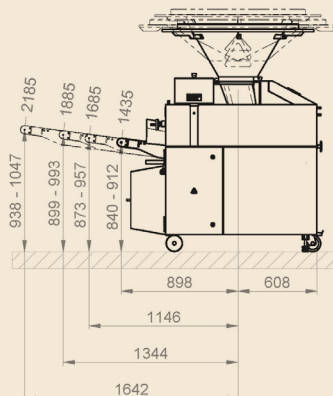
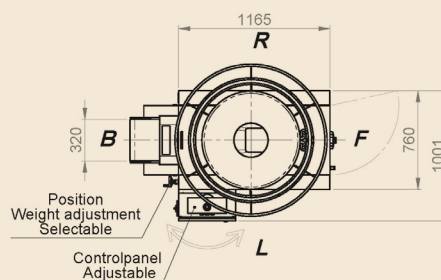
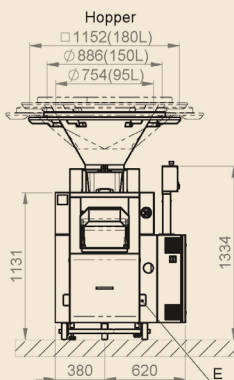
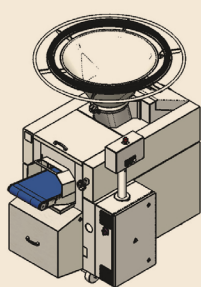

## V 300 Measurements

TYPE	WEIGHT RANGE	CAPACITY (FIXED)	CAPACITY VARIABLE	DIMENSIONS
1000	100 - 1200 gr	510, 650, 725, 810, 910, 1010, 1130 or 1270 pcs/h	507 - 1160 pcs/h	Length 1610 mm
1500	200 - 1800 gr		637 - 1456 pcs/h	Width 1010 mm
2000	400 - 2400 gr		700 - 1600 pcs/h	Height 1720 mm

## Options

- Hinged hopper stainless steel 150 or 180 litres
- Hopper inside Teflon coated
- Oiling on hopper including oil shortage signalisation
- PLC with touch panel with pre-set counter, recipe control, frequency inverter and Servo weight adjustment
- Discharge conveyor straight, 1885 or 2185 mm
- Lubrication on conveyor belt
- Mechanical flour duster
- Customer specific Blue Box

### WP HATON BV

Industrieterrein 13, 5981 NK Panningen, The Netherlands

Phone: +31 77307-1860, E-mail: [info@wp-haton.com](mailto:info@wp-haton.com)

[www.wp-haton.com](http://www.wp-haton.com)