



DOUGH  
DIVIDERS



# V 900 Dough Divider

**Industrial dough divider for high-speed dough  
make up lines.** A heavy-duty divider which is dough  
friendly at the same time to process all common dough.





## WP Haton the leading brand in dough processing since 1949

WP Haton produces the most advanced and best bread make-up machines in the world contributing to high weight accuracy, excellent structure and most friendly and careful handling of the dough without compromising on high speed, consistency and constant quality on every piece of the dough piece produced.

- Automated dough processing systems for virtually all types of bread
- Tailormade line concepts in dough processing equipment
- Unique system of modularization
- BreadLab: the experience center where bakers from all over the world can test our equipment with their own ingredients

# V 900 Dough Divider

### Highlights

- Heavy duty industrial divider
- Ni-Resist unit with food safe bronze pistons
- Voluminator for adjusting pressure to maintain airy structure of the dough
- Camshaft instead of crankshaft for high weight accuracy at high speed
- Long machine life with minimum down time and a high weight accuracy
- Oil catch tray underneath complete machine



## V 900

The V 900 dough divider is designed for high-speed dough make up lines and can be integrated in most classic bread lines. This heavy-duty dough divider is robustly designed yet at the same time dough friendly with a high weight accuracy. The V 900 can process a wide variety of dough types, including high water absorption dough and stiff dough. As the dough is portioned in a stand still position of the measuring pistons, high compression and equal filling of all pistons is guaranteed.

## Specifications

- 4, 5, 6, 7, 3 and 6, 4 and 8 pocket machine
- Dividing unit and main piston Ni-Resist with automatic oiling system, 12 adjustable dosing valves, oil tank
- Measuring piston in food safe bronze
- Knife made of hardened stainless steel
- Discharge conveyor cross 500 mm, with quick-lock system, scraper and catch tray
- Separate conveyor, easy connection/disconnection
- Separate drive on conveyor with gear motors including frequency inverter for variable speed
- Pneumatic discharge flap with synthetic scraper
- PLC with touch panel



Find out more about WP Haton and our products by scanning this QR-code with your mobile phone, or visit [WWW.WP-HATON.COM](http://WWW.WP-HATON.COM)

## Technical drawing

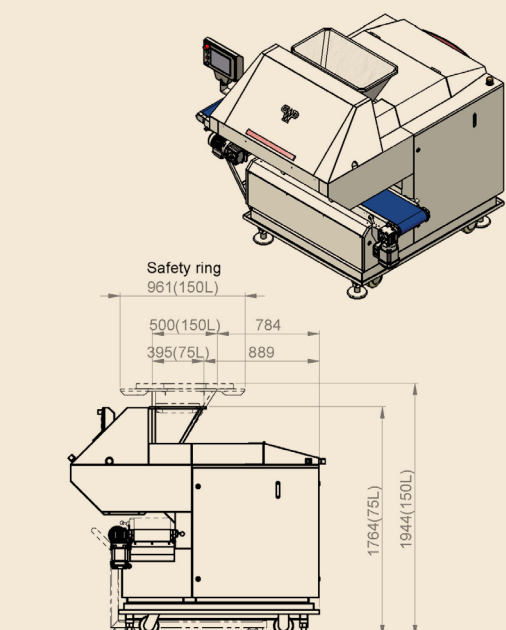
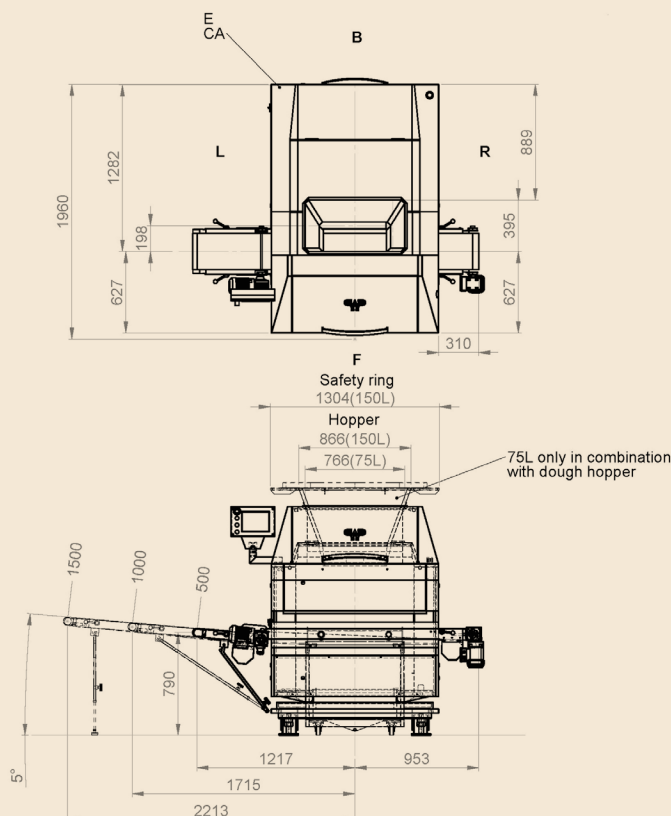

## V 900 Measurements

TYPE	PARTITIONS	WEIGHT RANGE	CAPACITY	DIMENSIONS
V 900 - 4	25 mm	200 - 1300 gr	2000 - 6000 pcs/h	Length 2410 mm
V 900 - 5	12,5 mm	200 - 1100 gr	2500 - 7500 pcs/h	Width 2000 mm
V 900 - 6	12,5 mm	150 - 890 gr	3000 - 9000 pcs/h	Height 1770 mm
V 900 - 7	12,5 mm	150 - 740 gr	3500 - 10500 pcs/h	
V 900 - 3/6	12,5 mm	300 - 1925 gr	1500 - 4500 pcs/h	
		150 - 890 gr	3000 - 9000 pcs/h	
V 900 - 4/8	12,5 mm	200 - 1400 gr	2000 - 6000 pcs/h	
		150 - 630 gr	4000 - 12000 pcs/h	

## Options

- Hopper stainless steel 75 litres, inside Teflon coated
- Hopper inside HDPE material
- Movable oil catch tray
- Customer specific Blue Box

### WP HATON BV

Industrieterrein 13, 5981 NK Panningen, The Netherlands

Phone: +31 77307-1860, E-mail: [info@wp-haton.com](mailto:info@wp-haton.com)

[www.wp-haton.com](http://www.wp-haton.com)